

5GVRLA

5GVRLA12 12V12Ah

5GVRLA series battery uses AGM technology and high-purity raw materials. Its good floating back up and large current discharge performance makes it optimal and economical choice for UPS/EPS.

Benefits

- Standard Commercial according to EUROBAT Classification
- Maximum charge efficiency
- High gas recombination efficiency
- Low self-discharge rate
- Easy installation and handling
- Vertical or horizontal installation

Applications

- UPS units
- Emergency power
- Starting generators
- EPS units

Standards

- IEC 61056-1/2
- JIS C8702-1/2
- EUROBAT guide

Drawing

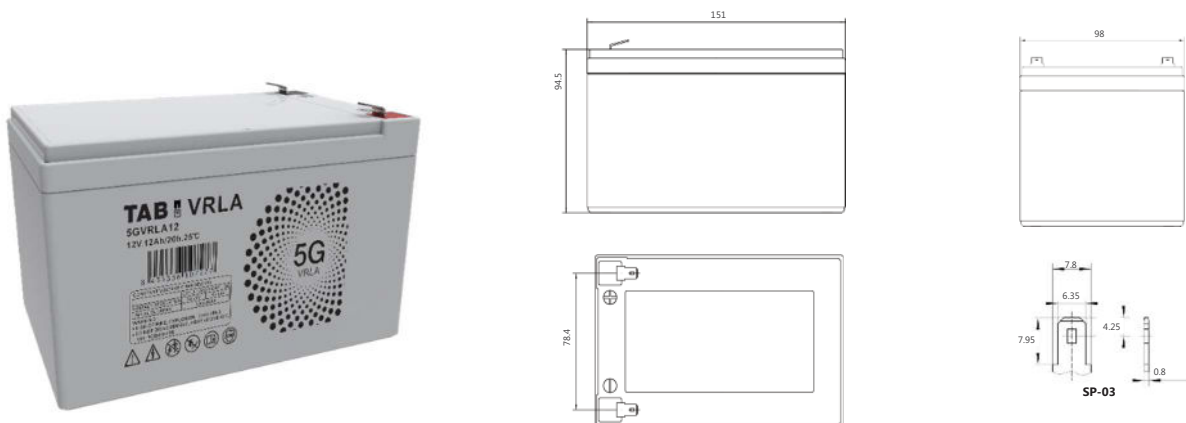

Specifications

Battery Model	5GVRLA12			
Design Life (years, 25°C)	5			
Capacity (Ah, 25°C)	20HR (0.60A, 1.75V)	10HR (1.1A, 1.75V)	5HR (1.92A, 1.75V)	1HR(7.49A, 1.70V)
	12	11	9.6	7.49
Dimensions (mm)	Length	Width	Height	Total Height
	151	98	94.5	100
Approx. Weight (kg)	3.57			
Reference Internal Resistance (mK)	14 (full charged @ 25°C)			
Maximum Discharge Current (A/5 Sec.)	180			
Self-Discharge (25°C)	≤3% per month			
Charge Voltage (V/cell, 25°C)	Cycle use		Float use	
	2.45 (-3.5mV/°C/cell), max charge current: 3.6 A		2.27 (-3.5mV/°C/cell)	
Short Circuit Current (A)	310			

Discharge Data

Constant Current Discharge Data (25°C, A)													
End Voltage (V/cell)	min						h						
	5	10	15	20	30	45	1	1.5	2	3	5	10	20
1.60	45.71	29.03	22.06	17.42	13.01	9.724	7.673	5.491	4.248	2.993	1.970	1.122	0.611
1.65	44.34	28.36	21.59	17.09	12.79	9.568	7.571	5.423	4.198	2.955	1.953	1.115	0.607
1.67	43.88	28.02	21.43	16.99	12.71	9.494	7.534	5.391	4.178	2.944	1.947	1.111	0.605
1.70	43.02	27.82	21.29	16.85	12.61	9.448	7.490	5.370	4.157	2.929	1.937	1.107	0.604
1.75	39.00	25.90	20.16	16.17	12.20	9.200	7.329	5.280	4.100	2.900	1.920	1.100	0.600
1.80	34.79	23.70	18.81	15.31	11.71	8.896	7.160	5.190	4.043	2.865	1.899	1.090	0.596

Constant Power Discharge Data (25°C, W/cell)													
End Voltage (V/cell)	min						h						
	5	10	15	20	30	45	1	1.5	2	3	5	10	20
1.60	83.57	54.50	41.90	33.39	25.16	18.96	15.05	10.81	8.390	5.933	3.917	2.237	1.220
1.65	81.30	53.42	41.13	32.86	24.80	18.71	14.89	10.71	8.311	5.871	3.890	2.228	1.215
1.67	80.57	53.11	40.99	32.81	24.72	18.60	14.83	10.66	8.285	5.854	3.884	2.222	1.212
1.70	79.15	52.58	40.70	32.49	24.54	18.52	14.76	10.63	8.252	5.832	3.868	2.217	1.211
1.75	72.22	49.10	38.66	31.30	23.82	18.10	14.47	10.47	8.155	5.785	3.842	2.206	1.205
1.80	64.76	45.07	36.25	29.79	22.94	17.53	14.19	10.32	8.061	5.725	3.807	2.190	1.200

Performance Curve

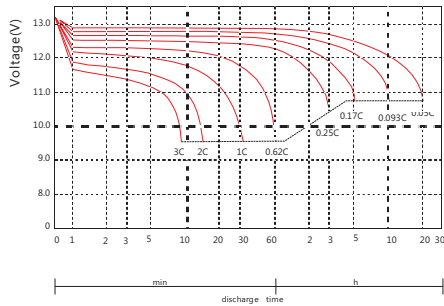

Discharge voltage vs. discharge time

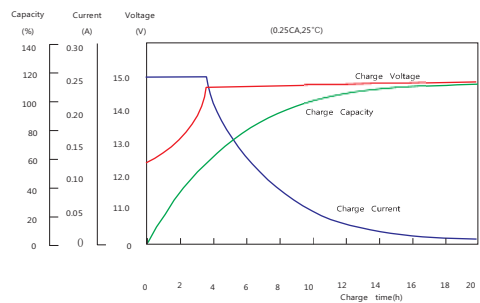

Charge capacity vs. charge time

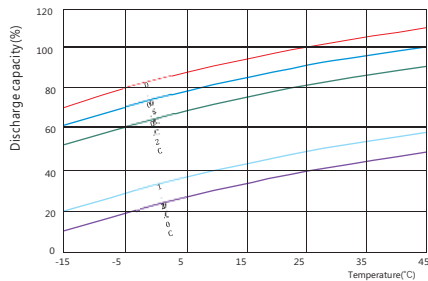

Discharge capacity vs. temperature

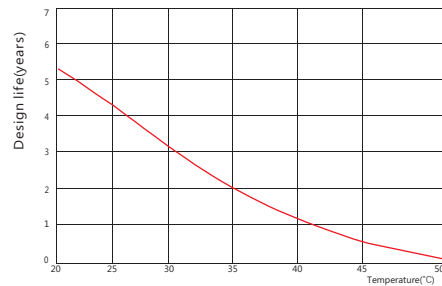

Design life vs. temperature